



Radio Communication Analyzer

MT8820C

LTE FDD/TDD Measurement Software

MX882012C/13C

LTE FDD/TDD Measurement Software Lite

MX882042C/43C



All-in-one Solution Supporting LTE FDD/TDD Terminal Development and Manufacturing

The LTE FDD Measurement Software MX882012C/LTE TDD Measurement Software MX882013C is designed for measuring the transmitter and receiver of 3.9G LTE FDD/TDD terminals.

When the LTE FDD Measurement Software MX882012C, W-CDMA Measurement Software MX882000C and GSM Measurement Software MX882001C are installed in the Radio Communication Analyzer MT8820C main frame, the Tx/Rx characteristics of 3 mode LTE FDD/W-CDMA/GSM terminals, which are becoming very popular worldwide, can be evaluated using a single MT8820C unit.

When the LTE FDD Measurement Software MX882012C and CDMA2000 Measurement Software MX882002C in the MT8820C, the Tx/Rx Characteristics of Dual mode LTE FDD/CDMA2000 terminals can be evaluated using a single MT8820C unit.

And manufacturing and inspection test times have been dramatically cut by incorporating advanced DSP and parallel measurement technologies.

Furthermore, several measurement items can be selected freely for batch measurement, and the number of measurements for each measurement item can be configured separately. The one-touch operation supports easy and quick measurement of Tx and Rx characteristics, including modulation analysis, transmit power, spectrum emission mask, adjacent channel leakage power ratio, and occupied bandwidth. The built-in GPIB and Ethernet interface enables the MT8820C to be integrated into automated test systems for after-sales maintenance, as well as into automated production lines.

Test	3GPP TS 36.521*1	Test Item
Transmitter Tests	6.2.2	UE Maximum Output Power
	6.2.2_1	UE Maximum Output Power for HPUE
	6.2.3	Maximum Power Reduction (MPR)
	6.2.3_1	Maximum Power Reduction (MPR) for HPUE
	6.2.4	Additional Maximum Power Reduction (A-MPR)
	6.2.4_1	Additional Maximum Power Reduction (A-MPR) for HPUE
	6.2.5	Configured UE transmitted Output Power
	6.2.5_1	Configured UE transmitted Output Power for HPUE
	6.3.2	Minimum Output Power
	6.3.3	Transmit OFF power
	6.3.4.1	General ON/OFF time mask
	6.3.4.2.1	PRACH time mask
	6.3.4.2.2	SRS time mask
	6.3.5.1	Power Control Absolute power tolerance
	6.3.5.2	Power Control Relative power tolerance
	6.3.5.3	Aggregate power control tolerance
	6.3.5_1.1	Power Control Absolute power tolerance for HPUE
	6.3.5_1.2	Power Control Absolute power tolerance for HPUE
6.3.5_1.3	Aggregate power control tolerance for HPUE	

Test	3GPP TS 36.521*1	Test Item
Transmitter Tests	6.5.1	Frequency Error
	6.5.2.1	Error Vector Magnitude (EVM)
	6.5.2.1A	PUSCH-EVM with exclusion period
	6.5.2.2	Carrier leakage
	6.5.2.3	In-band emissions for non allocated RB
	6.5.2.4	EVM equalizer spectrum flatness
	6.6.1	Occupied bandwidth
	6.6.2.1	Spectrum Emission Mask
	6.6.2.2	Additional Spectrum Emission Mask
	6.6.2.3	Adjacent Channel Leakage power Ratio
6.6.2.3_1	Adjacent Channel Leakage power Ratio for HPUE	
6.6.3.1	Transmitter Spurious emissions*2	
6.6.3.2	Spurious emission band UE co-existence*2	
6.6.3.3	Additional spurious emissions*2	
6.7	Transmit Intermodulation*2	
Receiver Tests	7.3	Reference Sensitivity Level
	7.4	Maximum input Level
	7.5	Adjacent Channel Selectivity (ACS)*2
	7.6.1	In-band blocking*2
	7.6.2	Out-of-band blocking*2
	7.6.3	Narrow band blocking*2
	7.7	Spurious response*2
	7.8.1	Wide band Intermodulation*2
	7.9	Spurious emissions*2

*1: 3GPP TS 36.521-1 V12.6.0 (2015-06)

*2: Requires external equipment (eg. Signal generator) for interference signal, etc.

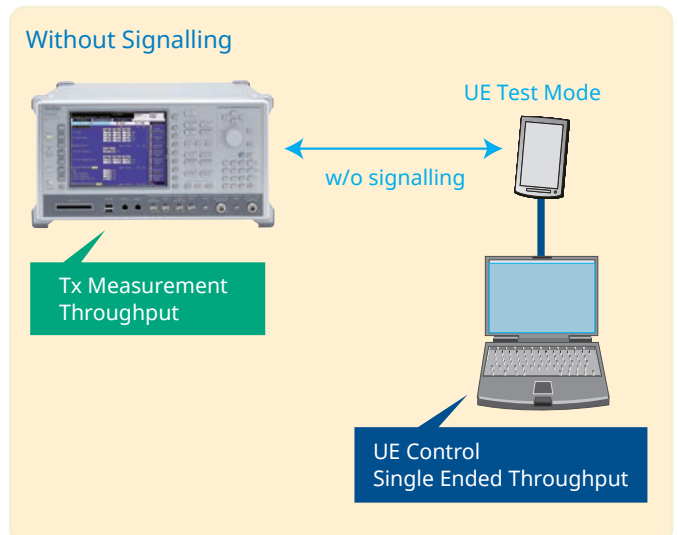
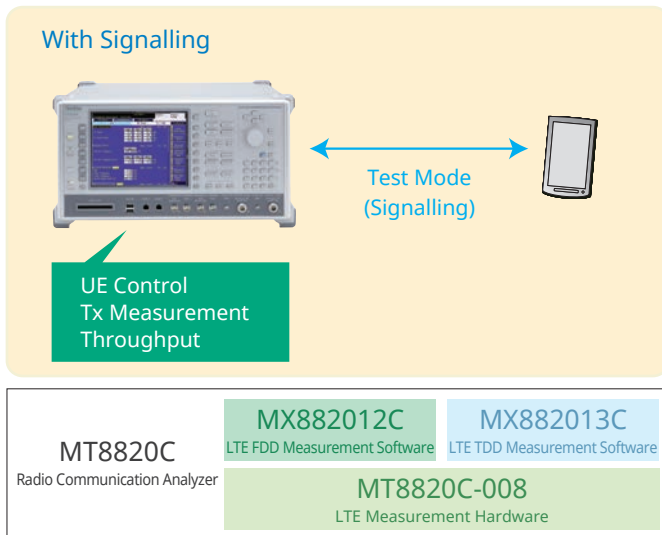

Example of LTE FDD and TDD configuration

LTE FDD/TDD Terminal Tx and Rx Measurement without Signalling

LTE Parameters

LTE RMC Signals

The MX882012C (MX882013C) supports UE category 1 to 5 (SISO) FRCs as TRx test signals for LTE FDD (LTE TDD) terminals.

In addition, it supports modulation uplink QPSK, 16QAM, and 64QAM methods as well as downlink QPSK, 16QAM, and 64QAM methods.

The maximum data rate can be output when connecting each SISO UE category.

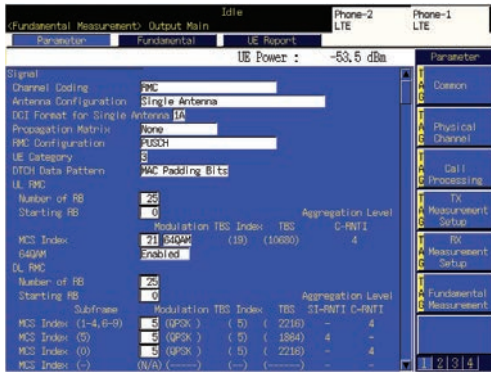

Transmitter Measurement

The transmit power, frequency error, occupied bandwidth, spectrum emission mask, adjacent channel leakage power ratio, modulation analysis, constellation, in-band emissions, and spectrum flatness can be measured.

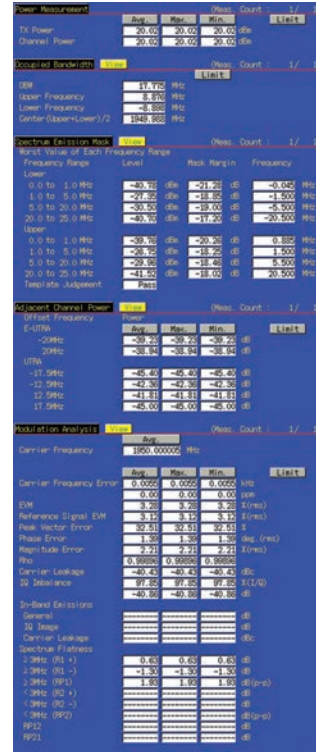

Power Measurements

Occupied Bandwidth

Spectrum Emission Mask

Adjacent Channel Leakage Power Ratio

Modulation Analysis

- Frequency Error
- EVM
- Phase Error
- Magnitude Error
- Carrier Leakage
- In-Band Emissions
- Spectrum Flatness

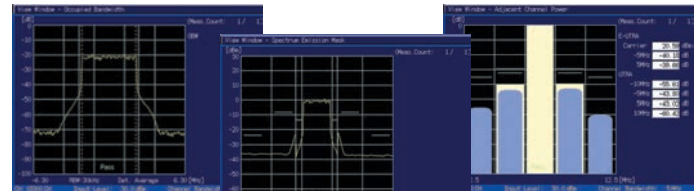

Occupied Bandwidth

Spectrum Emission Mask

Adjacent Channel Power

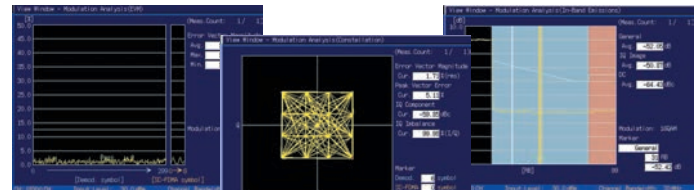

EVM

Constellation

In-Band Emissions (PartialRB)

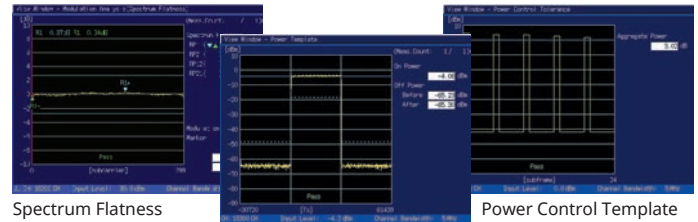

Spectrum Flatness

Power Template

Power Control Template (Aggregate)

LTE FDD/TDD Terminal Tx and Rx Measurement without Signalling

Receiver Measurement

LTE Throughput

The LTE throughput can be measured by counting the number of ACK blocks from the LTE FDD (TDD) terminal. In addition, statistical analysis can be performed based on CQI values reported by the LTE FDD (TDD) terminal.

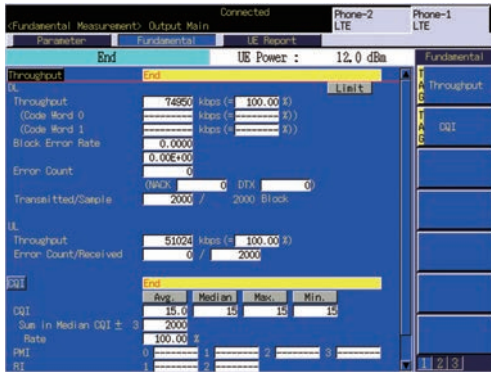

LTE FDD

Mobile Terminal Report Monitor

The LTE FDD (TDD) terminal status can be displayed as a periodic report sent from the LTE FDD (TDD) terminal to the MT8820C for checking IMSI and RSRP (Reference Signal Received Power). It also displays the L3 message trace.

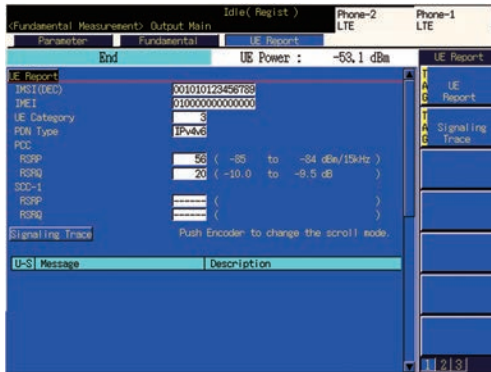

UE Report

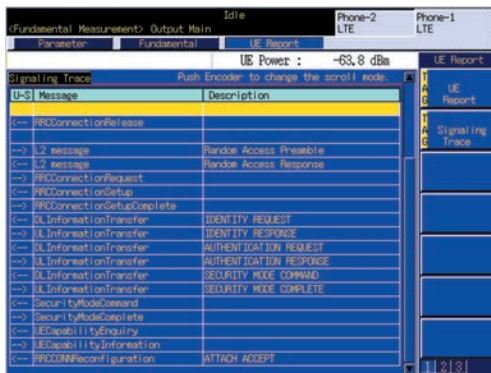

L3 Message Trace Information

One-touch Setting of Tx Test Items

Settings for 3GPP-compliant main Tx tests are made by one-touch operation. Evaluation starts when measurement is completed by pressing "Single", continuously, allowing even novices to perform accurate measurements successfully. In addition, control programs can be created simply and test speed can be faster using relevant GPIB commands.



For example, pressing **TX-1 Max. Power** and **QPSK Full RB** sets the parameters to measure the mobile terminal maximum output (QPSK Full RB) automatically and simultaneously. The overall evaluation, and Pass/Fail items (displayed in red) can be seen at a glance at measurement completion.

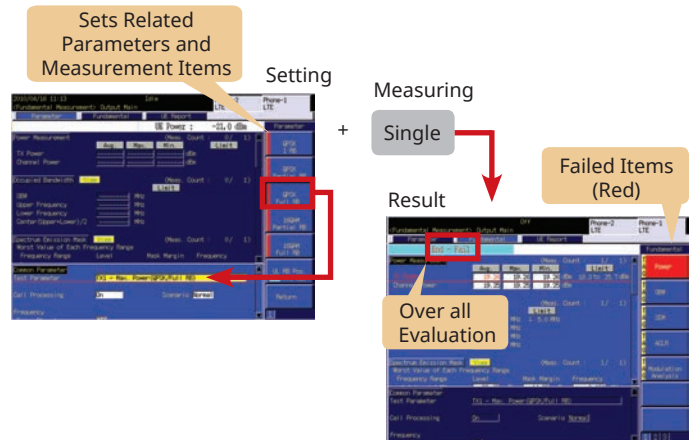

Packet Communication Data Transfer Test

The LTE FDD IP Data Transfer MX882012C-006 (LTE TDD IP Data Transfer MX882013C-006) option supports data transfer to/from external equipment via the Ethernet port. End-to-end data transfer between an application server connected to the MT8820C and the LTE FDD (TDD) terminal or client PC connected to the LTE FDD (TDD) terminal can be tested using the MX882012C-006 (MX882013C-006).

IP Data Transfer

The MT8820C sends IP packets from the LTE FDD (TDD) terminal to the application server. It also sends IP packets from the application server to the LTE FDD (TDD) terminal.

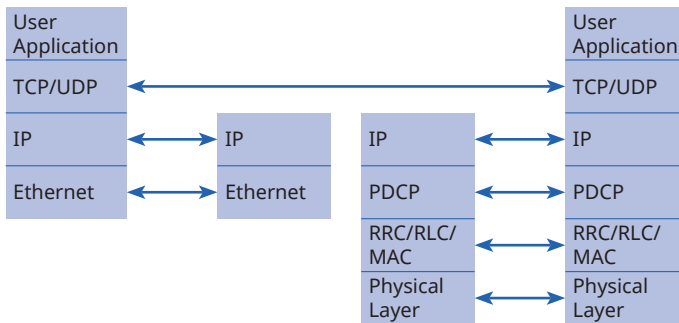

Protocol Stack for External IP Data Transfer Test

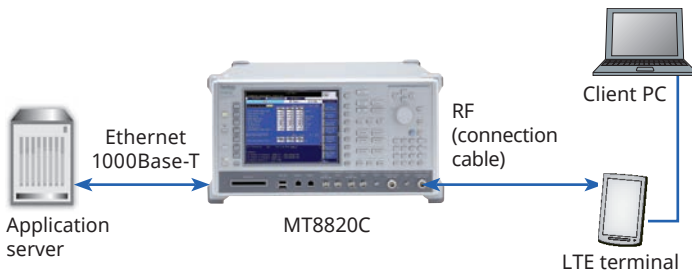

Example of MT8820C Connection

Measurement of Rx throughput in the 2x2 MIMO FDD (TDD) mode at Static Propagation is supported. Moreover, measurement at the maximum 2x2 MIMO Category 4 data rate is also supported.

LTE 2x2 MIMO

Rx Throughput Test

The LTE FDD 2x2 MIMO DL (LTE TDD 2x2 MIMO DL) option supports throughput measurements for 2x2 MIMO downlink signals connected with the MT8820C.

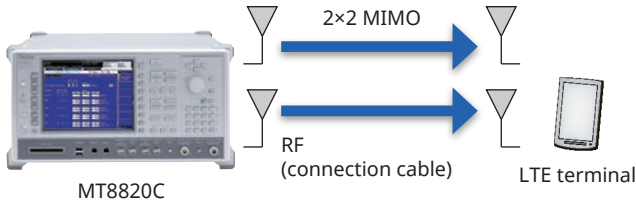

Example of MT8820C Connection

IP Data Transfer Test (2x2 MIMO)

Simultaneous installation of the MX882012C-006 LTE FDD IP Data Transfer option and the LTE FDD 2x2 MIMO DL option (MX882013C-006 LTE TDD IP Data Transfer option and the LTE TDD 2x2 MIMO DL option) supports connection with an external server and enables IP data communication at the maximum 2x2 MIMO Category 3 data rate.

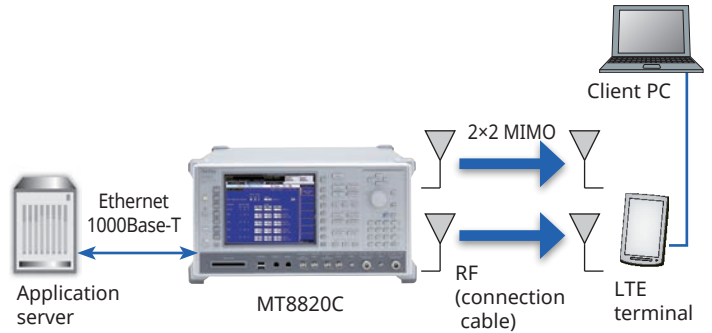

Example of MT8820C Connection

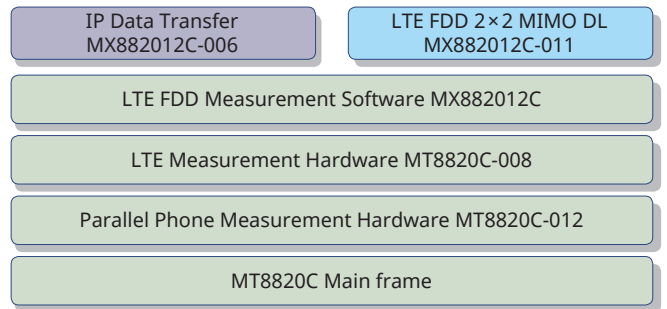

Example of IP Data Transfer (2x2 MIMO) Options Stack (LTE FDD)

LTE FDD CS Fallback to W-CDMA/GSM MX882012C-016
LTE FDD CS Fallback to CDMA2000 MX882012C-017
LTE TDD CS Fallback to W-CDMA/GSM MX882013C-016
LTE TDD CS Fallback to CDMA2000 MX882013C-017
LTE TDD CS Fallback to TD-SCDMA/GSM MX882013C-018

LTE CS Fall Back Tests

LTE CS Fallback option supports simple CS Fallback tests* (Redirection base) for LTE/3G/2G terminals connected to the MT8820C.

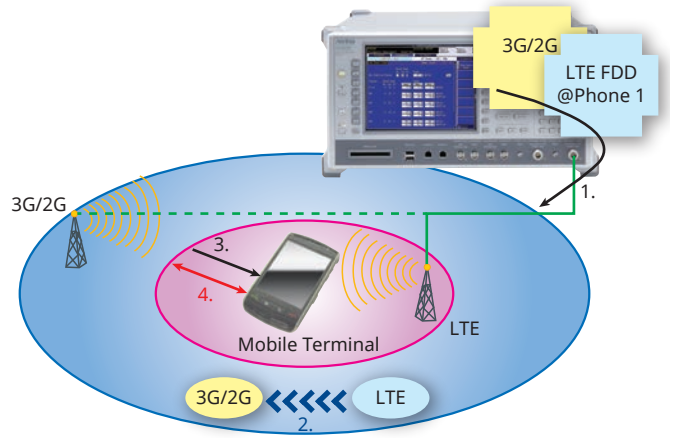
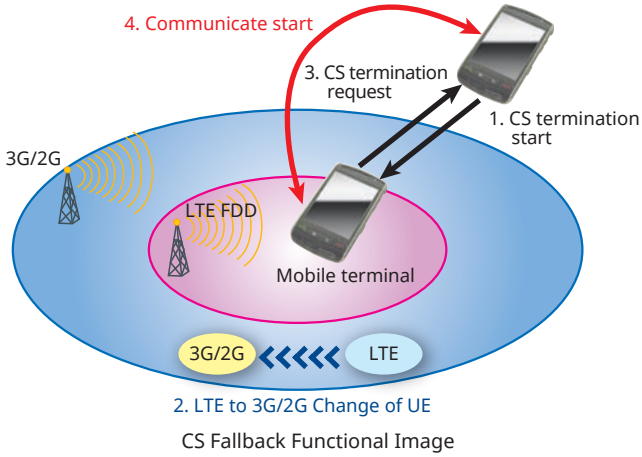

Connection Example with the MT8820C:
 MT8820C × 1 unit (supports 1 port CS Fallback function)



Connection Example with the MT8820C:
 MT8820C × 1 unit (supports parallel-phone measurements)

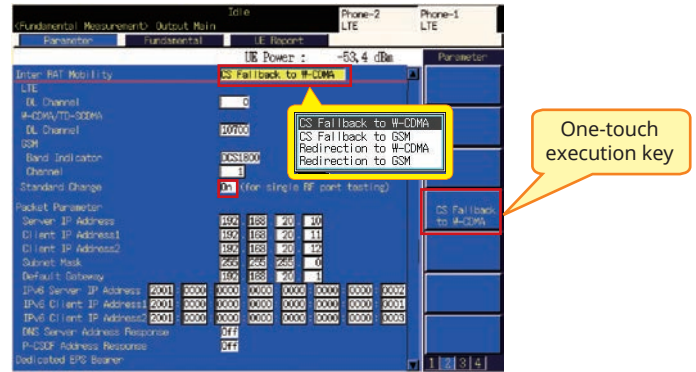

Example of MX882012C-016 Parameter



Example of MX882000C Parameter

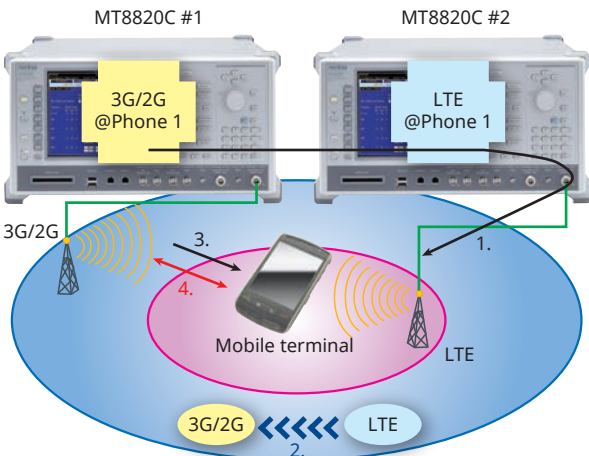

Connection Example with the MT8820C: MT8820C × 2 units

*: LTE/3G/2G mobile terminals must support CS Fallback function.

LTE-Advanced FDD DL CA Measurement Software MX882012C-021/ LTE-Advanced TDD DL CA Measurement Software MX882013C-021

The LTE-Advanced FDD/TDD DL CA Measurement Software MX882012C/13C-021 is designed for measuring the SISO receiver of LTE-Advanced terminals supporting Carrier Aggregation.

Test	3GPP TS 36.521-1*1	Test Items	
Receiver Tests	7.3A.1	Reference sensitivity level for CA (intra-band contiguous DL CA and UL CA)	No
	7.3A.2	Reference sensitivity level for CA (intra-band contiguous DL CA without UL CA)	Yes
	7.3A.3	Reference sensitivity level for CA (inter-band DL CA without UL CA)	Yes
	7.4A.1	Maximum input level for CA (intra-band contiguous DL CA and UL CA)	No
	7.4A.2	Maximum input level for CA (intra-band contiguous DL CA without UL CA)	Yes
	7.4A.3	Maximum input level for CA (inter-band DL CA without UL CA)	Yes
	7.4A.4	Maximum input level for CA (intra-band non-contiguous DL CA without UL CA)	Yes
	7.5A.1	Adjacent Channel Selectivity (ACS) for CA (intra-band contiguous DL CA and UL CA)	No
	7.5A.2	Adjacent Channel Selectivity (ACS) for CA (intra-band contiguous DL CA without UL CA)	Yes*2
	7.5A.3	Adjacent Channel Selectivity (ACS) for CA (inter-band DL CA without UL CA)	Yes*2
	7.5A.4	Adjacent Channel Selectivity (ACS) for CA (intra-band non-contiguous DL CA without UL CA)	Yes*2
	7.6.1A.1	In-band blocking for CA (intra-band contiguous DL CA and UL CA)	No
	7.6.1A.2	In-band blocking for CA (intra-band contiguous DL CA without UL CA)	Yes*2
	7.6.1A.3	In-band blocking for CA (inter-band DL CA without UL CA)	Yes*2
	7.6.1A.4	In-band blocking for CA (intra-band non-contiguous DL CA without UL CA)	Yes*2
	7.6.2A.1	Out-of-band blocking for CA (intra-band contiguous DL CA and UL CA)	No
	7.6.2A.2	Out-of-band blocking for CA (intra-band contiguous DL CA without UL CA)	Yes*2
	7.6.2A.3	Out-of-band blocking for CA (inter-band DL CA without UL CA)	Yes*2
	7.6.2A.4	Out-of-band blocking for CA (intra-band non-contiguous DL CA without UL CA)	Yes*2
	7.6.3A.1	Narrow band blocking for CA (intra-band contiguous DL CA and UL CA)	No
	7.6.3A.2	Narrow band blocking for CA (intra-band contiguous DL CA without UL CA)	Yes*2
	7.6.3A.3	Narrow band blocking for CA (inter-band DL CA without UL CA)	Yes*2
	7.6.3A.4	Narrow band blocking for CA (intra-band non-contiguous DL CA without UL CA)	Yes*2
	7.7A.1	Spurious response for CA (intra-band contiguous DL CA and UL CA)	No
	7.7A.2	Spurious response for CA (intra-band contiguous DL CA without UL CA)	Yes*2
	7.7A.3	Spurious response for CA (inter-band DL CA without UL CA)	Yes*2
	7.7A.4	Spurious response for CA (intra-band non-contiguous DL CA without UL CA)	Yes*2
	7.8.1A.1	Wideband intermodulation for CA (intra-band contiguous DL CA and UL CA)	No
	7.8.1A.2	Wideband intermodulation for CA (intra-band contiguous DL CA without UL CA)	Yes*2
	7.8.1A.3	Wideband intermodulation for CA (inter-band DL CA without UL CA)	Yes*2
	7.10A	Receiver image for CA	_*3

*1: 3GPP TS 36.521-1 V12.6.0 (2015-06)

*2: Requires external equipment (eg. signal generator) for interference signal, etc.

*3: TS 36.101 [2] clause 7.10.1A specifies minimum requirements for receiver image for CA but recommends that these requirements do not need to be tested.

LTE-Advanced FDD DL CA Measurement Software MX882012C-021/ LTE-Advanced TDD DL CA Measurement Software MX882013C-021

LTE-Advanced FDD/TDD DL CA Parameters

LTE RMC (DL CA) Signals

The MX882012C/13C-021 supports UE Category 6 (SISO, 2CC) FRCs as Rx test signals for LTE-Advanced FDD/TDD DL CA terminals. In addition, it supports modulation uplink QPSK and 16QAM methods as well as downlink QPSK, 16QAM, and 64QAM methods. The maximum data rate can be output when connecting each SISO UE category.

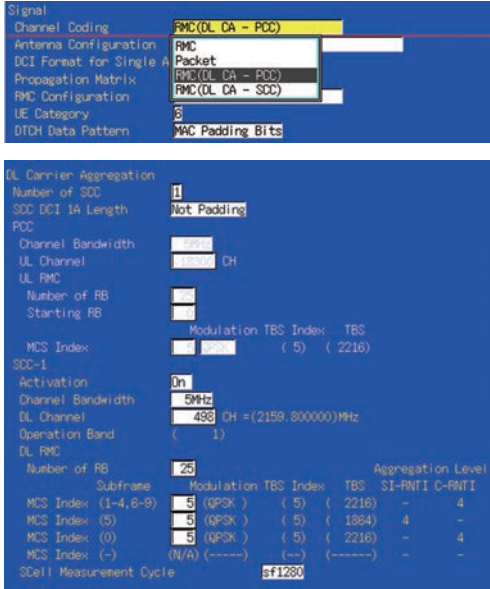

Test Parameter

✱CC: Component Carrier
✱CA: Carrier Aggregation

Receiver Measurement

LTE Throughput

The LTE throughput can be measured by counting the number of ACK blocks from the LTE-Advanced FDD/TDD DL CA terminal.

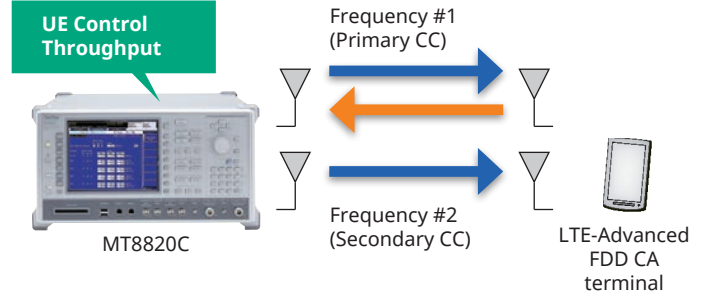

Example of MT8820C Connection

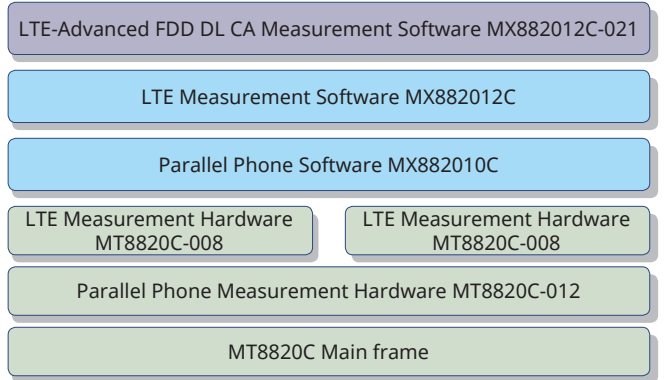

Example of LTE-Advanced FDD DL CA (2CC, SISO) Options Stack (LTE-Advanced FDD)

LTE-Advanced FDD DL CA IP Data Transfer MX882012C-026/ LTE-Advanced TDD DL CA IP Data Transfer MX882013C-026

Packet Communication Data Transfer Test

The LTE-Advanced FDD/TDD DL CA IP Data Transfer MX882012C/13C-026 supports data transfer to/from external equipment via the Ethernet port. End-to-end data transfer between two application servers connected to the MT8820C and the LTE-Advanced FDD/TDD DL CA terminal or Client PC connected to the LTE-Advanced FDD/TDD CA terminal can be tested using the MX882012C-026.*1, *2

IP Data Transfer (SISO)

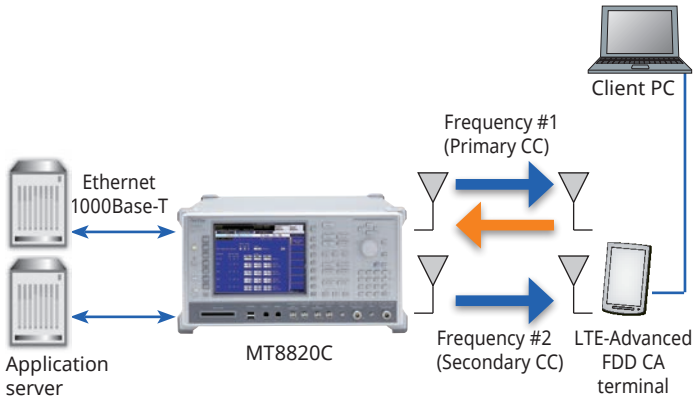

Example of MT8820C Connection

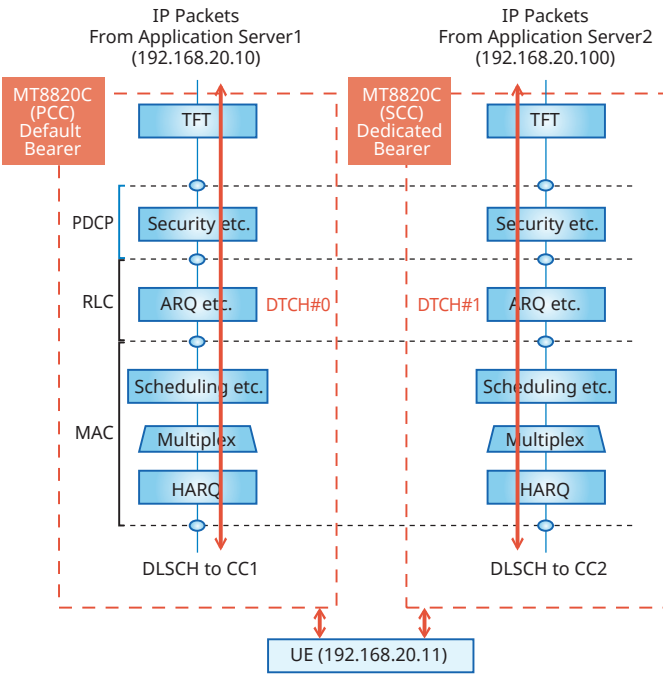

Layer2 Structure and Image of IP Data Streams

*1: To use the MX882012C/13C-026, the MX882012C/13C-006/021 should be installed.

*2: To test DL CA IP Data Transfer, it requires two application servers and two EPS bearers need to be established due to using two MT8820Cs (PCC, SCC) and UE should support the Multiple PDN Connection.

LTE-Advanced FDD DL CA 3CCs Measurement Software MX882012C-031/ LTE-Advanced TDD DL CA 3CCs Measurement Software MX882013C-031

The LTE-Advanced FDD/TDD DL CA 3CCs Measurement Software MX882012C/13-031 is designed for measuring the receiver of LTE-Advanced terminals supporting Carrier Aggregation.

Receiver Measurement

LTE Throughput

The LTE throughput can be measured by counting the number of ACK blocks from the LTE-Advanced FDD/TDD DL CA terminal.

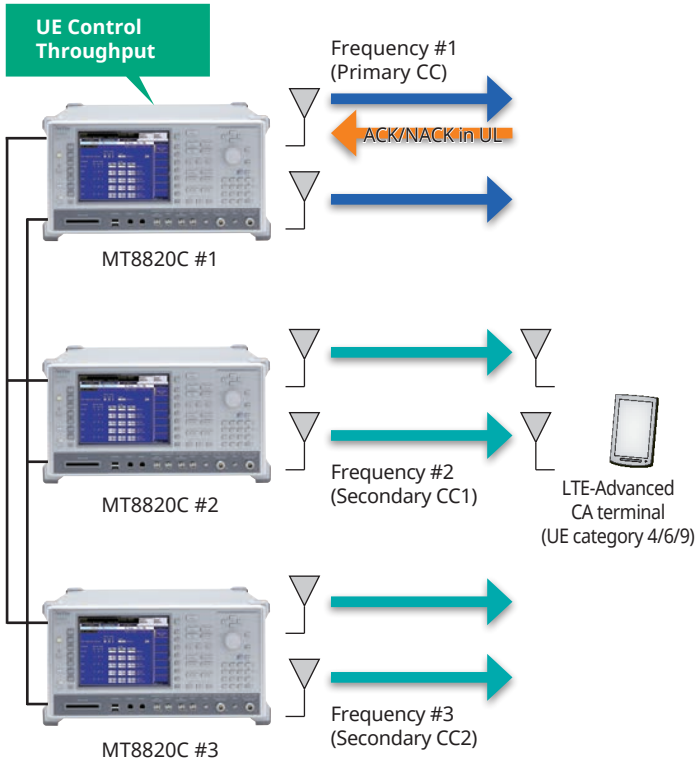

Example of MT8820C Connection (2x2 MIMO)

*: MIMO Test requires MT8820C 3 set.
MT8820C #1 requires MT8820C-008, MT8820C-012, MX882012C/13C, MX882012C/13C-011, MX882012C/13C-021, and MX882012C/13C-031.
MT8820C #2 and #3 requires MT8820C-008, MT8820C-012, MX882012C/13C, and MX882012C/13C-011.

LTE FDD/TDD Terminal Tx and Rx Measurement without Signalling

The MX882042C LTE FDD Measurement Software Lite, MX882043C LTE TDD Measurement Software Lite is designed for measuring the transmitter and receiver of 3.9G LTE FDD/TDD terminals.

Test	3GPP TS 36.521*1	Test Item
Transmitter Tests	6.2.2	UE Maximum Output Power
	6.2.2_1	UE Maximum Output Power for HPUE
	6.2.3	Maximum Power Reduction (MPR)
	6.2.3_1	Maximum Power Reduction (MPR) for HPUE
	6.2.4	Additional Maximum Power Reduction (A-MPR)*3
	6.2.4_1	Additional Maximum Power Reduction (A-MPR) for HPUE
	6.2.5	Configured UE transmitted Output Power*3
	6.2.5_1	Configured UE transmitted Output Power for HPUE
	6.3.2	Minimum Output Power
	6.5.1	Frequency Error
	6.5.2.1	Error Vector Magnitude (EVM)
	6.5.2.1A	PUSCH-EVM with exclusion period
	6.5.2.2	Carrier leakage
	6.5.2.3	In-band Emissions for Non-allocated RB
	6.5.2.4	EVM equalizer Spectrum Flatness
	6.6.1	Occupied Bandwidth
	6.6.2.1	Spectrum Emission Mask
6.6.2.2	Additional Spectrum Emission Mask*3	
6.6.2.3	Adjacent Channel Leakage Power Ratio	
6.6.2.3_1	Adjacent Channel Leakage power Ratio for HPUE	
Receiver Tests	7.3	Reference Sensitivity Level*4
	7.4	Maximum Input Level*4
	7.5	Adjacent Channel Selectivity (ACS)*2, *4
	7.6.1	In-band blocking*2, *4
	7.6.2	Out-of-band blocking*2, *4
	7.6.3	Narrow band blocking*2, *4
7.7	Spurious Response*2, *4	
7.8.1	Wideband Intermodulation*2, *4	

- *1: LTE FDD/TDD Non CP (DL ARB) only measures without signalling with DL signal generated by ARB. DUT must voluntarily output signal according to test spec because DUT control, such as payload data loopback and UL power control, not supported.
- *2: Requires external equipment (eg. Signal generator) for interference signal, etc.
- *3: Support power measurements only; fixed system information parameters on broadcast channel.
- *4: Output one frame length of DL RMC defined in 3GPP TS 36.521-1 AnnexA TableA.3.2-1 to A.3.2-4 repeatedly. Throughput measurement must be done in mobile terminal.

LTE FDD

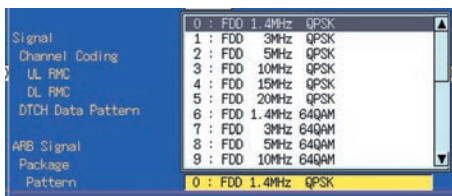

DL Signal Pattern (LTE FDD)



MT8820C
Radio Communication Analyzer

MX882042C
LTE FDD Measurement Software Lite

Tx Measurements

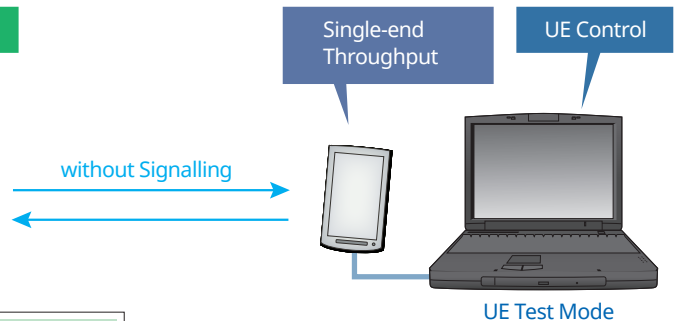

without Signalling

UE Test Mode

without Signalling

without Signalling

without Signalling

without Signalling

without Signalling

without Signalling

without Signalling

without Signalling

without Signalling

without Signalling

without Signalling

without Signalling

LTE Parameter

LTE RF Transmitter Measurement Signals

The MX882042C (MX882043C) software provides downlink-signal waveform patterns for test signals using the arbitrary waveform generation (ARB) function. Waveform patterns PAT0 to PAT11 can be selected for UE category 1 to 3 packages for use as LTE terminal Rx test signals*. In addition, test parameters supporting 3GPP TS 36.521-1 test items can be set.

*: MIMO is not supported. PAT0 to PAT11 are Anritsu fixed patterns.

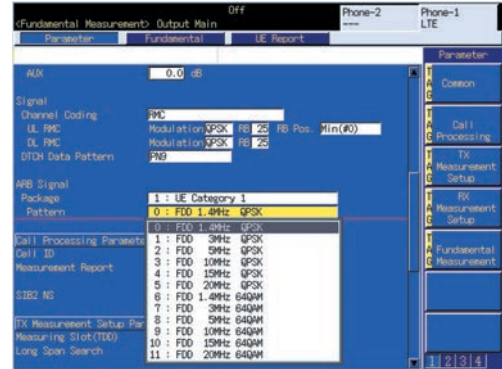

ARB Signal Pattern (LTE FDD)

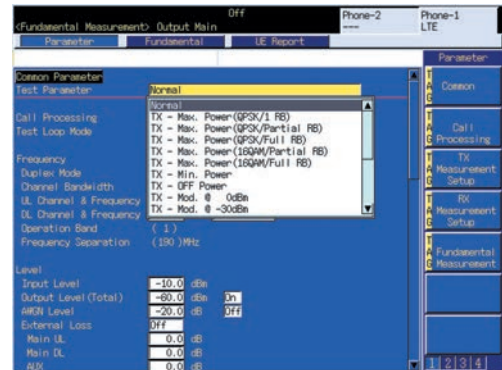

Test Pattern

Specifications

✦ Typical values are only for reference and are not guaranteed specifications.

LTE Measurement Hardware MT8820C-008

LTE FDD Measurement Software MX882012C, LTE TDD Measurement Software MX882013C

Modulation Analysis	<p>Frequency: 400 MHz to 2.7 GHz 3.4 GHz to 3.8 GHz (with MT8820C-018)</p> <p>Input level: -40 to +35 dBm (Main1)</p> <p>Carrier frequency accuracy: \pm (Set frequency \times Reference oscillator accuracy + 15 Hz)</p> <p>Modulation accuracy (residual vector error): $\leq 2.5\%$ (400 MHz to 2.7 GHz) (3.4 GHz to 3.8 GHz, 18° to 28°C) (Measurement count: 20)</p> <p>$\leq 3.0\%$ (3.4 GHz to 3.8 GHz, Measurement count: 20)</p> <p>In-Band Emissions: ≤ -40 dB (≥ -10 dBm, Allocated RB≤ 18)</p> <p>Measurement object: PUSCH, PRACH, PUCCH</p>
RF Power	<p>Frequency: 400 MHz to 2.7 GHz 3.4 GHz to 3.8 GHz (with MT8820C-018)</p> <p>Input level: -60 to +35 dBm (Main1)</p> <p>Measurement accuracy: 400 MHz to 2.7 GHz, After calibration, 10° to 40°C ± 0.5 dB, ± 0.3 dB (typ.) (-20 to +35 dBm), ± 0.7 dB (-50 to -20 dBm), ± 0.9 dB (-60 to -50 dBm)</p> <p>3.4 GHz to 3.8 GHz, After calibration, 10° to 40°C ± 0.5 dB, ± 0.3 dB (typ.) (-20 to +35 dBm, 18° to 28°C), ± 0.7 dB (-50 to +35 dBm), ± 0.9 dB (-60 to -50 dBm)</p> <p>Linearity: 400 MHz to 2.7 GHz, After calibration, 10° to 40°C ± 0.2 dB (-40 to 0 dB, ≥ -50 dBm), ± 0.4 dB (-40 to 0 dB, ≥ -60 dBm)</p> <p>3.4 GHz to 3.8 GHz, After calibration, 10° to 40°C ± 0.2 dB (-40 to 0 dB, ≥ -50 dBm, 18° to 28°C), ± 0.3 dB (-40 to 0 dB, ≥ -50 dBm), ± 0.4 dB (-40 to 0 dB, ≥ -60 dBm)</p> <p>Relative measurement error: < 2 dB ± 0.10 dB (typ., -40 to 0 dB, ≥ -50 dBm)</p> <p>Measurement object: PUSCH, PRACH, PUCCH</p>
Occupied Bandwidth	<p>Frequency: 400 MHz to 2.7 GHz 3.4 GHz to 3.8 GHz (with MT8820C-018)</p> <p>Input level: -10 to +35 dBm (Main1)</p>
Adjustment Channel Leakage Power Ratio	<p>Frequency: 400 MHz to 2.7 GHz 3.4 GHz to 3.8 GHz (with MT8820C-018)</p> <p>Input level: -10 to +35 dBm (Main1)</p> <p>Measurement point: E-UTRA ACLR1, UTRA ACLR1, UTRA ACLR2</p> <p>Measurement range: ≥ 45 dB (E-UTRA ACLR1), ≥ 50 dB (UTRA ACLR1), ≥ 55 dB (UTRA ACLR2)</p>
Spectrum Emission Mask	<p>Frequency: 400 MHz to 2.7 GHz 3.4 GHz to 3.8 GHz (with MT8820C-018)</p> <p>Input level: -10 to +35 dBm (Main1)</p>
RF Signal Generator	<p>Output frequency: 400 MHz to 2.7 GHz (1 Hz steps) 3.4 GHz to 3.8 GHz (with MT8820C-018)</p> <p>AWGN level: Off, -20 to +5 dB [0.1 dB steps, Relative level between Ior (Total power) and AWGN]</p> <p>AWGN level accuracy: ± 0.2 dB (Relative level between Ior AWGN)</p>
Throughput Measurement	<p>Function: Throughput measurement according to Reference Measurement Channel (RMC)</p> <p>Measurement object: ACK and NACK data imposed on uplink from terminal</p>
Call Processing	<p>Call controlling: Registration, Call processing for Reference Measurement Channel (executes each processing conforming to 3GPP standards and performs pass/fail evaluation)</p> <p>Mobile terminal controlling: Output level (executes each mobile terminal control conforming to 3GPP standards)</p>

LTE FDD IP Data Transfer MX882012C-006, LTE TDD IP Data Transfer MX882013C-006

Function	Uses Ethernet port of LTE measurement hardware to transfer data to external devices
----------	-------------------------------------------------------------------------------------

LTE FDD 2x2 MIMO DL MX882012C-011, LTE TDD 2x2 MIMO DL MX882013C-011

Function	Measures Rx performance of 2x2 MIMO mobile terminals
RF Signal Generator	Output frequency: 400 MHz to 2.7 GHz (1 Hz steps) 3.4 GHz to 3.8 GHz (with MT8820C-018)
Throughput Measurement	Function: Throughput measurement using RMC Measurement target: ACK and NACK reported from UE

LTE FDD CS Fallback to W-CDMA/GSM MX882012C-016, LTE TDD CS Fallback to W-CDMA/GSM MX882013C-016

Function	This can be used to perform CS Fallback to W-CDMA or GSM using two MT8820Cs.
----------	------------------------------------------------------------------------------

LTE FDD CS Fallback to CDMA2000 MX882012C-017, LTE TDD CS Fallback to CDMA2000 MX882013C-017

Function	This can be used to perform CS Fallback to CDMA2000 using two MT8820Cs.
----------	-------------------------------------------------------------------------

LTE TDD CS Fallback to TD-SCDMA/GSM MX882013C-018

Function	This can be used to perform CS Fallback to TD-SCDMA or GSM using two MT8820Cs.
----------	--------------------------------------------------------------------------------

Specifications

LTE-Advanced FDD DL CA Measurement Software MX882012C-021, LTE-Advanced TDD DL CA Measurement SoftwareMX882013C-021

Function	RX Measurements in compliance with 3GPP TS 36.521-1 Chapter 7 (DL 2CCs, UL 1CCs) test standards. RF Max Throughput Measurement (@physical layer) Supports RF Max throughput tests with 2x2 MIMO DL for LTE-Advanced FDD/TDD CA when it combine MX882012C/13C-011 LTE FDD/TDD 2x2 MIMO DL option.
RF Signal Generator	Output frequency: 400 MHz to 2.7 GHz (1 Hz steps) 3.4 GHz to 3.8 GHz (with MT8820C-018)
Throughput Measurement	Function: Throughput measurement using RMC Measurement target: ACK and NACK reported from UE

LTE-Advanced FDD DL CA IP Data Transfer MX882012C-026 , LTE-Advanced TDD DL CA IP Data Transfer MX882013C-026

Function	IP data transfer with external devices by using the Ethernet port of the LTE measurement hardware is available in DL CA.
----------	--------------------------------------------------------------------------------------------------------------------------

LTE-Advanced FDD DL CA 3CCs Measurement Software MX882012C-031

Function	The reception measurements of DL 3CCs and UL 1CC and the maximum throughput tests are available. By using with the MX882012C-011 LTE FDD 2x2 MIMO DL option, the maximum throughput test of DL CA 2x2 MIMO is available.
RF Signal Generator	Output frequency: 400 MHz to 2700 MHz (1 Hz per step) 3400 MHz to 3800 MHz (with MT8820C-018)
Throughput Measurement	Function: Throughput measurement using RMC Measurement target: ACK and NACK reported from UE

LTE-Advanced TDD DL CA 3CCs Measurement Software MX882013C-031

Function	The reception measurements of DL 3CCs and UL 1CC and the maximum throughput tests are available. By using with the MX882013C-011 LTE TDD 2x2 MIMO DL option, the maximum throughput test of DL CA 2x2 MIMO is available.
RF Signal Generator	Output frequency: 400 MHz to 2700 MHz (1 Hz per step) 3400 MHz to 3800 MHz (with MT8820C-018)
Throughput Measurement	Function: Throughput measurement using RMC Measurement target: ACK and NACK reported from UE

LTE FDD Measurement Software Lite MX882042C, LTE TDD Measurement Software Lite MX882043C

Modulation Analysis	Frequency: 400 MHz to 2.7 GHz 3.4 GHz to 3.8 GHz (with MT8820C-018) Input level: -40 to +35 dBm (Main1) Carrier frequency accuracy: \pm (Set frequency \times Reference oscillator accuracy + 15 Hz) Modulation accuracy (residual vector error): $\leq 2.5\%$ (400 MHz to 2.7 GHz) (3.4 GHz to 3.8 GHz, 18° to 28°C) (Measurement count: 20) $\leq 3.0\%$ (3.4 GHz to 3.8 GHz, Measurement count: 20) In-Band Emissions: ≤ -40 dB (≥ -10 dBm, Allocated RB ≤ 18) Measurement object: PUSCH
RF Power	Frequency: 400 MHz to 2.7 GHz 3.4 GHz to 3.8 GHz (with MT8820C-018) Input level: -60 to +35 dBm (Main1) Measurement accuracy: 400 MHz to 2.7 GHz, After calibration, 10° to 40°C ± 0.5 dB, ± 0.3 dB (typ.)(-20 to +35 dBm), ± 0.7 dB (-50 to -20 dBm), ± 0.9 dB (-60 to -50 dBm) 3.4 GHz to 3.8 GHz, After calibration, 10° to 40°C ± 0.5 dB, ± 0.3 dB (typ.)(-20 to +35 dBm, 18° to 28°C), ± 0.7 dB (-50 to +35 dBm), ± 0.9 dB (-60 to -50 dBm) Linearity: 400 MHz to 2.7 GHz, After calibration, 10° to 40°C ± 0.2 dB (-40 to 0 dB, ≥ -50 dBm), ± 0.4 dB (-40 to 0 dB, ≥ -60 dBm) 3.4 GHz to 3.8 GHz, After calibration, 10° to 40°C ± 0.2 dB (-40 to 0 dB, ≥ -50 dBm, 18° to 28°C), ± 0.3 dB (-40 to 0 dB, ≥ -50 dBm), ± 0.4 dB (-40 to 0 dB, ≥ -60 dBm) Relative measurement error: Less than 2 dB ± 0.10 dB (typ., -40 to 0 dB, ≥ -50 dBm) Measurement object: PUSCH
Occupied Bandwidth	Frequency: 400 MHz to 2.7 GHz 3.4 GHz to 3.8 GHz (with MT8820C-018) Input level: -10 to +35 dBm (Main1)
Adjustment Channel Leakage Power Ratio	Frequency: 400 MHz to 2.7 GHz 3.4 GHz to 3.8 GHz (with MT8820C-018) Input level: -10 to +35 dBm (Main1) Measurement point: E-UTRA ACLR1, UTRA ACLR1, UTRA ACLR2 Measurement range: ≥ 45 dB (E-UTRA ACLR1), ≥ 50 dB (UTRA ACLR1), ≥ 55 dB (UTRA ACLR2)
Spectrum Emission Mask	Frequency: 400 MHz to 2.7 GHz 3.4 GHz to 3.8 GHz (with MT8820C-018) Input level: -10 to +35 dBm (Main1)

Ordering Information

Please specify the model/order number, name and quantity when ordering.
The names listed in the chart below are Order Names. The actual name of the item may differ from the Order Name.

Model/Order No.	Name
MT8820C	Main frame Radio Communication Analyzer
	Standard accessories
	Power Cord: 1 pc
	CF Card: 1 pc
	PC Card Adapter (For CF card): 1 pc
W3320AE	MT8820C Operation Manual (CD-ROM): 1 pc
	Options
MT8820C-017	Extended RF Hardware*1
MT8820C-001	W-CDMA Measurement Hardware
MT8820C-002	TDMA Measurement Hardware
MT8820C-003	CDMA2000 Measurement Hardware
MT8820C-007	TD-SCDMA Measurement Hardware
MT8820C-008	LTE Measurement Hardware
MT8820C-011	Audio Board
MT8820C-012	Parallel Phone Measurement Hardware
MT8820C-018	Extended RF 3.4 GHz to 3.8 GHz (requires MT8820C-017, MT8820C-119, or MT8820C-120)
MT8820C-043	CDMA2000 Time Offset CAL for GPS SG (requires MT8820C-003 and MX882002C)
MT8820C-101	W-CDMA Measurement Hardware Retrofit
MT8820C-102	TDMA Measurement Hardware Retrofit
MT8820C-103	CDMA2000 Measurement Hardware Retrofit
MT8820C-107	TD-SCDMA Measurement Hardware Retrofit
MT8820C-108	LTE Measurement Hardware Retrofit
MT8820C-111	Audio Board Retrofit
MT8820C-112	Parallel Phone Measurement Hardware Retrofit
MT8820C-119	Extended RF Hardware for SPM Retrofit
MT8820C-120	Extended RF Hardware for PPM Retrofit
MT8820C-143	CDMA2000 Time Offset CAL for GPS SG Retrofit (requires MT8820C-003 and MX882002C)
MT8820C-177	TD-SCDMA Measurement Retrofit (requires MT8820C-001)
	Software options
MX882000C	W-CDMA Measurement Software (requires MT8820C-001 and MX88205xC)
MX882000C-001	W-CDMA Voice Codec (requires MT8820C-011 and MX882000C)
MX882000C-011	HSDPA Measurement Software (requires MT8820C-001, MX882000C, and MX882050C)
MX882000C-013	HSDPA High Data Rate (requires MT8820C-001, MX882000C, MX882000C-011, and MX882050C)
MX882000C-021	HSUPA Measurement Software (requires MT8820C-001, MX882000C, MX882000C-011, and MX882050C)
MX882000C-031	HSPA Evolution Measurement Software*2 (requires MT8820C-001, MX882000C, MX882000C-011, MX882000C-021, and MX882050C)
MX882000C-032	DC-HSDPA Measurement Software*2, *3 (requires MT8820C-001 (2 sets), MT8820C-012, MX882000C, MX882000C-011, MX882000C-021, MX882000C-031, MX882010C, and MX882050C)
MX882000C-033	DC-HSUPA Measurement Software*2, *4 (requires MT8820C-001 (2 sets), MT8820C-012, MX882000C, MX882000C-011, MX882000C-021, MX882000C-031, MX882000C-032, MX882010C, MX882050C)
MX882000C-034	4C-HSDPA Measurement Software*2, *4 (requires MT8820C-001 (2 sets), MT8820C-012, MX882000C, MX882000C-011, MX882000C-021, MX882000C-031, MX882000C-032, MX882010C, MX882050C)
MX882001C	GSM Measurement Software (requires MT8820C-002)
MX882001C-001	GSM Voice Codec (requires MT8820C-011 and MX882001C)
MX882001C-002	GSM External Packet Data (requires MX882001C)
MX882001C-011	EGPRS Measurement Software (requires MX882001C)
MX882001C-041	GSM High-speed Adjustment (requires MX882001C)
MX882002C	CDMA2000 Measurement Software (requires MT8820C-003)
MX882002C-001	CDMA2000 Voice Codec (requires MT8820C-011 and MX882002C)
MX882002C-002	CDMA2000 External Packet Data (requires MX882002C)
MX882005C	PHS Measurement Software (requires MT8820C-002)
MX882005C-011	Advanced PHS Measurement Software (requires MX882005C)
MX882007C	TD-SCDMA Measurement Software (requires MT8820C-001 and MT8820C-007)
MX882007C-001	TD-SCDMA Voice Codec (requires MT8820C-011 and MX882007C)
MX882007C-003	TD-SCDMA Video Phone Test (requires MX882007C)
MX882007C-011	TD-SCDMA HSDPA Measurement Software*2 (requires MT8820C-001, MT8820C-007, and MX882007C)
MX882007C-012	TD-SCDMA HSDPA Evolution Measurement Software*2 (requires MT8820C-001, MT8820C-007, MX882007C, MX882007C-011)
MX882007C-021	TD-SCDMA HSUPA Measurement Software*2 (requires MT8820C-001, MT8820C-007, MX882007C, MX882007C-011)

Model/Order No.	Name
MX882010C	Parallel Phone Measurement Software*5 [requires MT8820C-012, the two same measurement hardware (2 board/set) and one measurement software]
MX882012C	LTE FDD Measurement Software*2 (requires MT8820C-008)
MX882012C-006	LTE FDD IP Data Transfer*2 (requires MX882012C)
MX882012C-011	LTE FDD 2x2 MIMO DL*2, *6 (requires MT8820C-012 and MX882012C)
MX882012C-016	LTE FDD CS Fallback to W-CDMA/GSM*7 (requires MX882012C)
MX882012C-017	LTE FDD CS Fallback to CDMA2000*7 (requires MX882012C)
MX882012C-021	LTE-Advanced FDD DL CA Measurement Software*2, *8 (requires MT8820C-008 (2 sets), MT8820C-012, MX882010C, and MX882012C)
MX882012C-026	LTE-Advanced FDD DL CA IP Data Transfer*9 (requires MT8820C-008 (2 sets), MT8820C-012, MX882010C, MX882012C, MX882012C-006, MX882012C-021)
MX882012C-031	LTE-Advanced FDD DL CA 3CCs Measurement Software*2, *10 (requires MT8820C 2 sets. One is required MT8820C-008 (2 sets), MT8820C-012, MX882010C, MX882012C and MX882012C-021. The other is required MT8820C-008, MX882012C.)
MX882013C	LTE TDD Measurement Software*2 (requires MT8820C-008)
MX882013C-006	LTE TDD IP Data Transfer*2 (requires MX882013C)
MX882013C-011	LTE TDD 2x2 MIMO DL*2, *6 (requires MT8820C-012 and MX882013C)
MX882013C-016	LTE TDD CS Fallback to W-CDMA/GSM*11 (requires MX882013C)
MX882013C-017	LTE FDD CS Fallback to CDMA2000*7 (requires MX882013C)
MX882013C-018	LTE TDD CS Fallback to TD-SCDMA/GSM*11 (requires MX882013C)
MX882013C-021	LTE-Advanced TDD DL CA Measurement Software*2, *8 (requires MT8820C-008 (2 sets), MT8820C-012, MX882010C, and MX882013C)
MX882013C-026	LTE-Advanced TDD DL CA IP Data Transfer*9 (requires MT8820C-008 (2 sets), MT8820C-012, MX882010C, MX882013C, MX882013C-006, MX882013C-021)
MX882013C-031	LTE-Advanced TDD DL CA 3CCs Measurement Software*2, *10 (requires MT8820C 2 sets. One is required MT8820C-008 (2 sets), MT8820C-012, MX882010C, MX882013C, MX882013C-006, MX882013C-021. The other is required MT8820C-008, MX882013C.)
MX882032C	CDMA2000 Measurement Software Lite*2
MX882036C	1xEV-DO Measurement Software Lite*2
MX882036C-011	1xEV-DO Rev. A Measurement Software*2
MX882042C	LTE FDD Measurement Software Lite*2
MX882043C	LTE TDD Measurement Software Lite*2
MX882050C	W-CDMA Call Processing Software*2, *12 (requires MX882000C)
MX882050C-002	W-CDMA External Packet Data*2 (requires MX882050C)
MX882050C-003	W-CDMA Video Phone Test*2 (requires MX882050C)
MX882050C-007	W-CDMA Band XII, XIII, XIV, XIX, XX, XXI*2, *13 (requires MX882050C)
MX882050C-008	W-CDMA Band XI*2 (requires MX882050C)
MX882050C-009	W-CDMA Band IX*2 (requires MX882050C)
MX882050C-011	HSDPA External Packet Data*2 (requires MX882000C-011)
MX882051C	W-CDMA Call Processing Software*2 (requires MX882000C)
MX882051C-002	W-CDMA External Packet Data*2 (requires MX882051C)
MX882051C-003	W-CDMA Video Phone Test*2 (requires MX882051C)
MX882070C	W-CDMA Ciphering Software*2 (requires MX882050C)
MX882071C	W-CDMA Ciphering Software*2 (requires MX882051C)
	Warranty
MT8820C-ES210	2 years Extended Warranty Service
MT8820C-ES310	3 years Extended Warranty Service
MT8820C-ES510	5 years Extended Warranty Service
	Application parts
P0035B	W-CDMA/GSM Test USIM
P0035B7	W-CDMA/GSM Test USIM*14
P0135A6	Anritsu Test UICC GA (Nano UICC size)*15
P0135A7	Anritsu Test UICC GA (Micro UICC size)*15
P0250A6	Anritsu Test UICC GT (Nano UICC size)*15
P0250A7	Anritsu Test UICC GT (Micro UICC size)*15
P0260A6	Anritsu Test UICC GM (Nano UICC size)*15
P0260A7	Anritsu Test UICC GM (Micro UICC size)*15
P0135B6	Anritsu Test UICC GA (Nano UICC size)*15
P0135B7	Anritsu Test UICC GA (Micro UICC size)*15
P0250B6	Anritsu Test UICC GT (Nano UICC size)*15
P0250B7	Anritsu Test UICC GT (Micro UICC size)*15
P0260B6	Anritsu Test UICC GM (Nano UICC size)*15
P0260B7	Anritsu Test UICC GM (Micro UICC size)*15
A0058A	Handset

Model/Order No.	Name
J1195A J1249	PP2S Output Cable CDMA2000 Cable [D-Sub (15 pin, P-type) · D-Sub (15 pin, P-type), used in combination with J1267 (sold separately)]*16
J1267	CDMA2000 Cross Cable [D-Sub (9 pin, P-type) · D-Sub (9 pin, P-type), reverse cable used in combination with J1249 (sold separately)]
J1606A J0576B J0576D J0127A J0127C J0007 J0008 MN8110B B0332 B0643A B0499 B0499B	Cable*16 Coaxial Cord, 1 m (N-P · 5D-2W · N-P) Coaxial Cord, 2 m (N-P · 5D-2W · N-P) Coaxial Cord, 1 m (BNC-P · RG58A/U · BNC-P) Coaxial Cord, 0.5 m (BNC-P · RG58A/U · BNC-P) GPIB Cable, 1 m GPIB Cable, 2 m I/O Adapter (for call processing I/O) Joint Plate (4 pcs/set) Rack Mount Kit (MT8820C) Carrying Case (Hard type) (with protective cover and casters) Carrying Case (Hard type) (with protective cover, without casters)

- *1: MT8820C-017 has been a standard option that MT8820C are shipped with until July 2012 (Simultaneous order is required MT8820C and MT8820C-017).
- *2: For terminal connectivity, contact your Anritsu sales representative.
- *3: MX882000C-032 is required a Parallelphone measurement configuration of W-CDMA HSPA Evolution.
For use MT8820C 2 units, contact your Anritsu sales representative.
- *4: MX882000C-033 (034) is required W-CDMA DC-HSDPA configuration.
- *5: The following measurement hardware supports the Parallelphone measurement option: MT8820C-001, MT8820C-002, MT8820C-003, MT8820C-007, MT8820C-008.
All the measurement hardware can be installed simultaneously.

- *6: MX882012C-011 is required MT8820C-012.
- *7: The MX882012C-016 (017) LTE FDD CS Fallback to W-CDMA/GSM (CDMA2000) requires a separate MT8820C with the W-CDMA/GSM (CDMA2000) configuration. Contact your Anritsu sales representative for the CS Fallback function test configuration.
- *8: MX882012C (12C)-021 is required a Parallelphone measurement configuration of LTE FDD (TDD).
For Use MT8820C 2 units, contact your Anritsu sales representative.
- *9: MX882012C (13C)-026 function test is required external server PCs (2 sets).
LTE Advanced FDD (TDD) DL CA IP Data Transfer (2CCs, 2Layer) is required
MT8820C LTE 2x2 MIMO DL configuration (2 sets) and external server PCs (2 sets).
- *10: One is required LTE FDD (TDD) ParallelPhone Configuration.
The other is required LTE FDD Single Phone Configuration.
For use MT8820C 3 units, contact your Anritsu sales representative.
A synchronized cable is required too.
- *11: The MX882013C-016 (018) LTE TDD CS Fallback to W-CDMA/GSM (TD-SCDMA/GSM) requires a separate MT8820C with the W-CDMA/GSM (TD-SCDMA/GSM) configuration. Contact your Anritsu sales representative for the CS Fallback function test configuration.
- *12: These options preinstall the integrity protection function.
- *13: MX882050C-007 supports W-CDMA Band 12, 13, 14, 19, 20, 21.
- *14: The P0035B7 MicroSIM is a cut-down P0035B W-CDMA/GSM Test USIM. The P0035B7 Test USIM is a microSIM. It CANNOT be used in a normal size USIM card slot. A commercial SIM adapter CANNOT be used with the P0035B7. If used, it may jam and break in the terminal.
- *15: Refer to the P0135Ax/P0250Ax/P0260Ax leaflet for details.
- *16: J1267 (J1606A) cable can use for LTE-Advanced DLCA synchronized cable.
Contact your Anritsu sales representative for details.

Parallelphone™ is a registered trademark of Anritsu Corporation.
CF® card is a registered trademark of SanDisk Corporation in the United States and is licensed to CFA (Compact Flash Association).



Specifications are subject to change without notice.

● United States

Anritsu Company

1155 East Collins Blvd., Suite 100, Richardson,
TX 75081, U.S.A.
Toll Free: 1-800-267-4878
Phone: +1-972-644-1777
Fax: +1-972-671-1877

● Canada

Anritsu Electronics Ltd.

700 Silver Seven Road, Suite 120, Kanata,
Ontario K2V 1C3, Canada
Phone: +1-613-591-2003
Fax: +1-613-591-1006

● Brazil

Anritsu Eletrônica Ltda.

Praça Armadeu Amaral, 27 - 1 Andar
01327-010 - Bela Vista - São Paulo - SP - Brazil
Phone: +55-11-3283-2511
Fax: +55-11-3288-6940

● Mexico

Anritsu Company, S.A. de C.V.

Av. Ejército Nacional No. 579 Piso 9, Col. Granada
11520 México, D.F., México
Phone: +52-55-1101-2370
Fax: +52-55-5254-3147

● United Kingdom

Anritsu EMEA Ltd.

200 Capability Green, Luton, Bedfordshire, LU1 3LU, U.K.
Phone: +44-1582-433200
Fax: +44-1582-731303

● France

Anritsu S.A.

12 avenue du Québec, Bâtiment Iris 1- Silic 612,
91140 VILLEBON SUR YVETTE, France
Phone: +33-1-60-92-15-50
Fax: +33-1-64-46-10-65

● Germany

Anritsu GmbH

Nemetschek Haus, Konrad-Zuse-Platz 1
81829 München, Germany
Phone: +49-89-442308-0
Fax: +49-89-442308-55

● Italy

Anritsu S.r.l.

Via Elio Vittorini 129, 00144 Roma, Italy
Phone: +39-6-509-9711
Fax: +39-6-502-2425

● Sweden

Anritsu AB

Kistagången 20B, 164 40 KISTA, Sweden
Phone: +46-8-534-707-00
Fax: +46-8-534-707-30

● Finland

Anritsu AB

Teknobulevardi 3-5, FI-01530 VANTAA, Finland
Phone: +358-20-741-8100
Fax: +358-20-741-8111

● Denmark

Anritsu A/S

Kay Fiskers Plads 9, 2300 Copenhagen S, Denmark
Phone: +45-7211-2200
Fax: +45-7211-2210

● Russia

Anritsu EMEA Ltd.

Representation Office in Russia
Tverskaya str. 16/2, bld. 1, 7th floor.
Moscow, 125009, Russia
Phone: +7-495-363-1694
Fax: +7-495-935-8962

● Spain

Anritsu EMEA Ltd.

Representation Office in Spain
Edificio Cuzco IV, Po. de la Castellana, 141, Pta. 8
28046, Madrid, Spain
Phone: +34-915-726-761
Fax: +34-915-726-621

● United Arab Emirates

Anritsu EMEA Ltd.

Dubai Liaison Office

902, Aurora Tower,
P O Box: 500311- Dubai Internet City
Dubai, United Arab Emirates
Phone: +971-4-3758479
Fax: +971-4-4249036

● India

Anritsu India Private Limited

2nd & 3rd Floor, #837/1, Binnamangla 1st Stage,
Indiranagar, 100ft Road, Bangalore - 560038, India
Phone: +91-80-4058-1300
Fax: +91-80-4058-1301

● Singapore

Anritsu Pte. Ltd.

11 Chang Charn Road, #04-01, Shriro House
Singapore 159640
Phone: +65-6282-2400
Fax: +65-6282-2533

● P.R. China (Shanghai)

Anritsu (China) Co., Ltd.

Room 2701-2705, Tower A,
New Caohejing International Business Center
No. 391 Gui Ping Road Shanghai, 200233, P.R. China
Phone: +86-21-6237-0898
Fax: +86-21-6237-0899

● P.R. China (Hong Kong)

Anritsu Company Ltd.

Unit 1006-7, 10/F., Greenfield Tower, Concordia Plaza,
No. 1 Science Museum Road, Tsim Sha Tsui East,
Kowloon, Hong Kong, P.R. China
Phone: +852-2301-4980
Fax: +852-2301-3545

● Japan

Anritsu Corporation

8-5, Tamura-cho, Atsugi-shi, Kanagawa, 243-0016 Japan
Phone: +81-46-296-6509
Fax: +81-46-225-8359

● Korea

Anritsu Corporation, Ltd.

5FL, 235 Pangyoyeok-ro, Bundang-gu, Seongnam-si,
Gyeonggi-do, 463-400 Korea
Phone: +82-31-696-7750
Fax: +82-31-696-7751

● Australia

Anritsu Pty. Ltd.

Unit 20, 21-35 Ricketts Road,
Mount Waverley, Victoria 3149, Australia
Phone: +61-3-9558-8177
Fax: +61-3-9558-8255

● Taiwan

Anritsu Company Inc.

7F, No. 316, Sec. 1, NeiHu Rd., Taipei 114, Taiwan
Phone: +886-2-8751-1816
Fax: +886-2-8751-1817